

IT 认证电子书



质 量 更 高 服 务 更 好

半年免费升级服务

<http://www.itrenzheng.com>

Exam : **300-620**

Title : Implementing Cisco
Application Centric
Infrastructure (DCACI)

Version : DEMO

1.An engineer is implementing a Cisco ACI data center network that includes Cisco Nexus 2000 Series 10G fabric extenders.

Which physical topology is supported?

A)

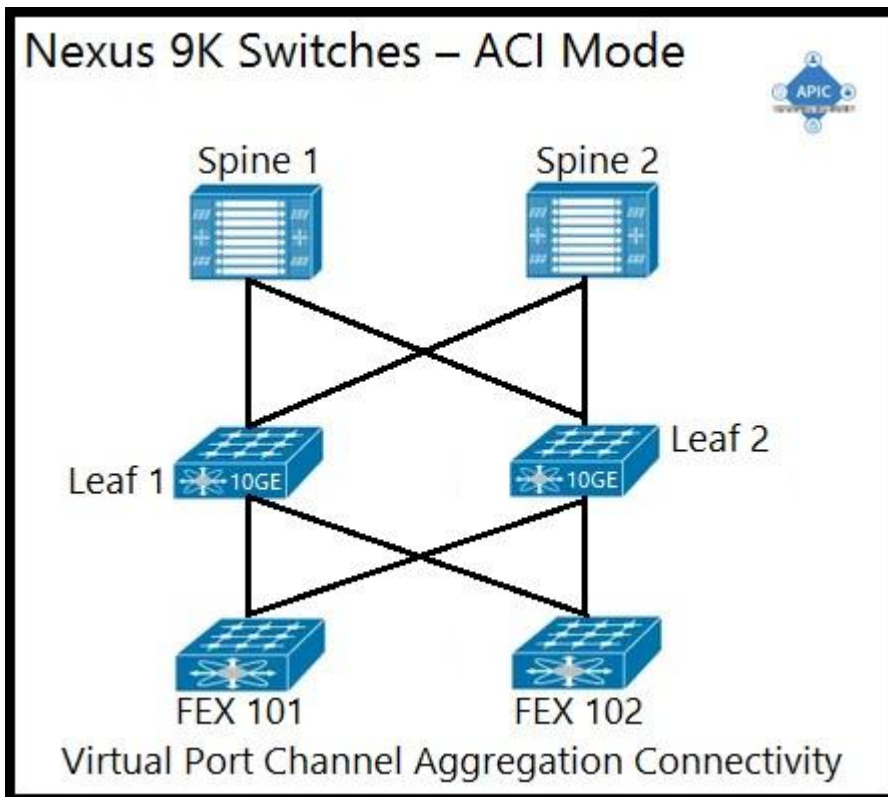

B)

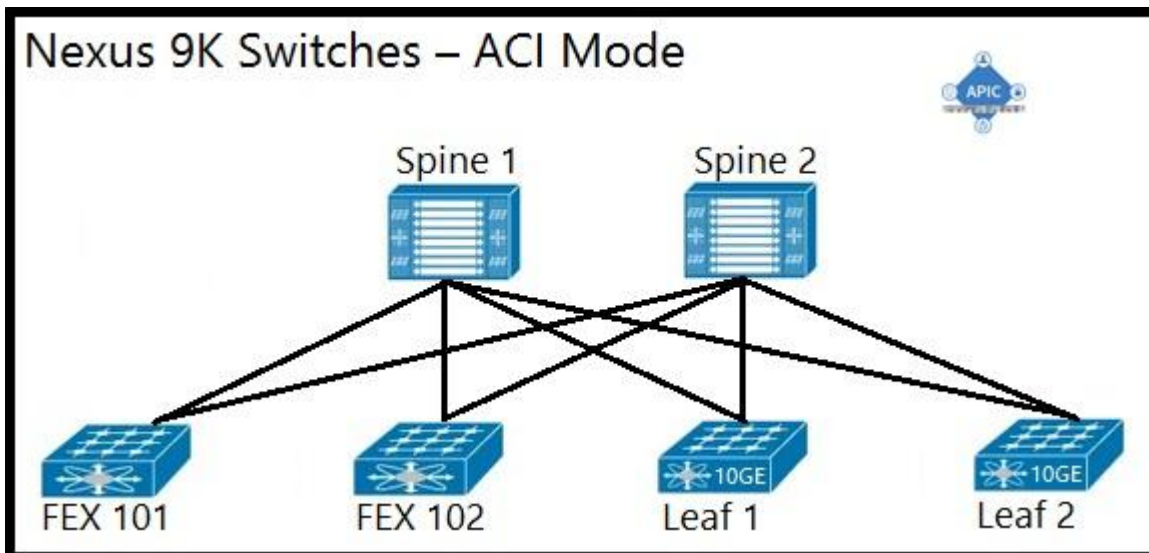

C)

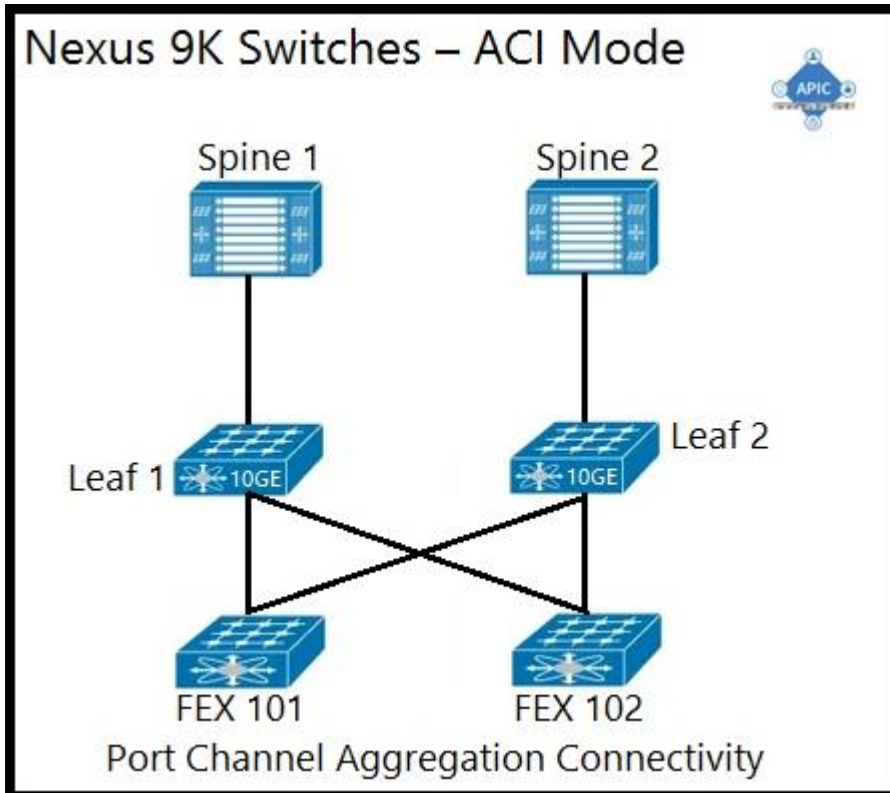

D)

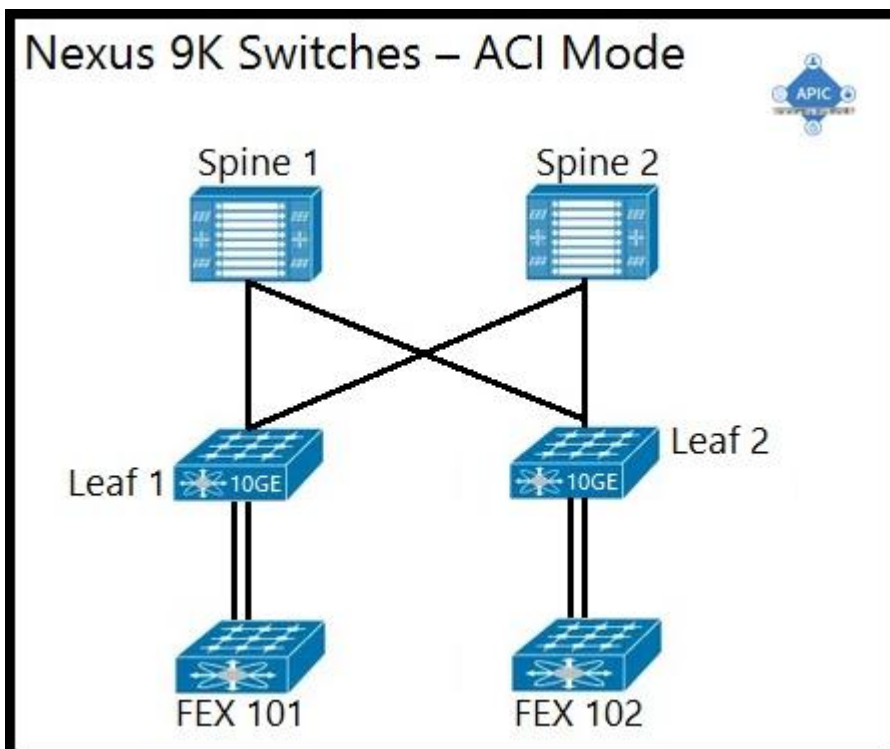

- A. Option A
- B. Option B
- C. Option C
- D. Option D

Answer: A

Explanation:

The supported physical topology for a Cisco ACI data center network that includes Cisco Nexus 2000 Series 10G fabric extenders is depicted in Option A. This topology illustrates a pair of spine switches connected to leaf switches, which are then connected to the fabric extenders. The Cisco Nexus 2000 Series Fabric Extenders act as remote line cards for a parent Cisco Nexus switch, extending the network fabric. The topology shown is a spine-leaf architecture, which is a scalable, high-bandwidth framework that is typical in ACI deployments.

Reference: For a detailed understanding of the ACI fabric and supported topologies, you can refer to the Cisco Application Centric Infrastructure Design Guide, which provides comprehensive information on design recommendations and deployment models: Cisco ACI Design Guide.

To learn more about the role of fabric extenders in the ACI architecture, the following resource offers insights into how they integrate with the ACI fabric: Understanding the ACI Fabric.

2.An ACI administrator notices a change in the behavior of the fabric.

Which action must be taken to determine if a human intervention introduced the change?

- A. Inspect event records in the APIC UI to see all actions performed by users.
- B. Inspect /var/log/audit_messages on the APIC to see a record of all user actions.
- C. Inspect audit logs in the APIC UI to see all user events.
- D. Inspect the output of show command history in the APIC CLI.

Answer: C

Explanation:

To determine if a change in the behavior of the ACI fabric was due to human intervention, an ACI administrator should inspect the audit logs in the APIC UI. The audit logs provide a record of all user events, which includes actions performed by users, making it possible to trace any changes back to specific human activities¹.

3.An engineer is creating a configuration import policy that must terminate if the imported configuration is incompatible with the existing system.

Which import mode achieves this result?

- A. merge
- B. atomic
- C. best effort
- D. replace

Answer: B

Explanation:

The import mode that must be used to ensure that the import process terminates if the imported configuration is incompatible with the existing system is the 'atomic' mode. This mode ignores shards that contain objects that cannot be imported while proceeding with shards that can be imported. If the incoming configuration's version is incompatible with the existing system, the import process will terminate².

Reference: https://www.cisco.com/c/en/us/td/docs/switches/datacenter/aci/apic/sw/4-x/aci-fundamentals/Cisco-ACI-Fundamentals-401/Cisco-ACI-Fundamentals-401_chapter_01011.html

4.Which components must be configured for the BGP Route Reflector policy to take effect?

- A. spine fabric interface overrides and profiles
- B. access policies and profiles
- C. pod policy groups and profiles
- D. leaf fabric interface overrides and profiles

Answer: D

Explanation:

For the BGP Route Reflector policy to take effect, the components that must be configured are the leaf fabric interface overrides and profiles. These configurations are necessary to establish the route reflector relationships within the BGP protocol on the leaf switches

Reference: https://www.cisco.com/c/en/us/td/docs/switches/datacenter/aci/apic/sw/4-x/L3-configuration/Cisco-APIC-Layer-3-Networking-Configuration-Guide-401/Cisco-APIC-Layer-3-Networking-Configuration-Guide-401_chapter_01.html

5.Which type of policy configures the suppression of faults that are generated from a port being down?

- A. fault lifecycle assignment
- B. event lifecycle assignment
- C. fault severity assignment
- D. event severity assignment

Answer: C

Explanation:

The type of policy that configures the suppression of faults generated from a port being down is the 'fault severity assignment' policy. This policy allows administrators to change the severity of a fault or suppress it altogether, which can be useful for managing expected faults and reducing noise from non-critical events

Reference:

https://www.cisco.com/c/en/us/td/docs/switches/datacenter/aci/apic/sw/all/faults/guide/b_APIC_Faults_Errors/b_IFC_Faults_Errors_chapter_01.html