

# IT 认证电子书



质 量 更 高 服 务 更 好

半年免费升级服务

<http://www.itrenzheng.com>

**Exam** : **642-812**

**Title** : Building Cisco Multilayer  
Switched Networks

**Version** : Demo

1: Which three statements about the Multiple Spanning Tree (MST) protocol (IEEE 802.1s) are true? (Choose three.)

- A.An MST region is a group of MST switches that appear as a single virtual bridge to adjacent CST and MST regions.
- B.All switches in an MST region, except distribution layer switches, should have their priority lowered from the default value 32768.
- C.All switches in the same MST region must have the same VLAN-to-instance mapping, but different configuration revision numbers.
- D.Enabling MST with the spanning-tree mode mst global configuration command also enables RSTP.
- E.To verify the MST configuration, the show pending command can be used in MST configuration mode.
- F.When RSTP and MSTP are configured, UplinkFast and BackboneFast must also be enabled.

Answer: A D E

2: A client is searching for an access point (AP). What is the correct process order that the client and access point go through to create a connection?

- A.probe request/response, authentication request/response, association request/response
- B.association request/response, authentication request/response, probe request/response
- C.probe request/response, association request/response, authentication request/response
- D.association request/response, probe request/response, authentication request/response

Answer: A

3: Which three features are part of the Cisco Compatible Extensions program? (Choose three.)

- A.security
- B.routing and switching
- C.VLAN and QoS
- D.analog and digital voice
- E.accounting
- F.mobility

Answer: A C F

4: Refer to the exhibit. Switch S2 contains the default configuration. Switches S1 and S3 both have had the command spanning-tree mode rapid-pvst issued on them. What will be the result?

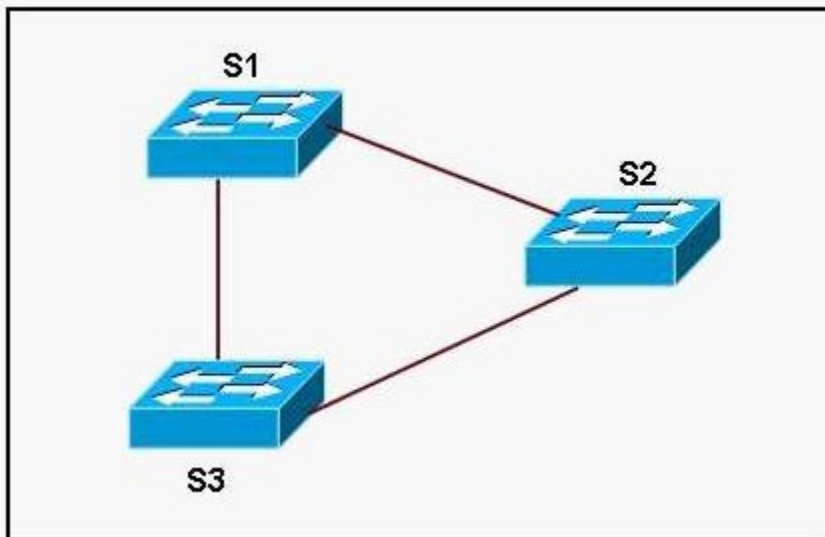

- A.Switches S1 and S3 will be able to exchange traffic but neither will be able to exchange traffic with Switch S2
- B.Switches S1, S2, and S3 will be able to pass traffic between themselves. However, if there is a topology change, Switch S2 will not receive notification of the change.
- C.Switches S1, S2, and S3 will be able to pass traffic between themselves.
- D.IEEE 802.1D and IEEE 802.1w are incompatible. All three switches must use the same standard or no traffic will pass between any of the switches.

Answer: C

5: What are two methods of mitigating MAC address flooding attacks? (Choose two.)

- A.Place unused ports in a common VLAN.
- B.Implement private VLANs.
- C.Implement DHCP snooping.
- D.Implement port security.
- E.Implement VLAN access maps.

Answer: D E

6: Which statement is true about IP telephony calls?

- A.A Voice over IP (VoIP) packet consists of the voice payload, IP header, TCP header, RTP header, and Layer 2 link header.
- B.The voice carrier stream uses H.323 to set up, maintain, and tear down call endpoints.
- C.Call control signaling uses Real-Time Transport Protocol (RTP) packets that contain actual voice samples.
- D.The sum of bandwidth necessary for each major application, including voice, video, and data, should not exceed 75 percent of the total available bandwidth for each link.

Answer: D

7: Examine the router output above. Which two items are correct? (Choose two.)

```
RouterA# show standby
Ethernet0/1 - Group 1
  State is Active
    2 state changes, last state change 00:30:59
  virtual IP address is 10.1.0.20
    Secondary virtual IP address 10.1.0.21
  Active virtual MAC address is 0004.4d82.7981
    Local virtual MAC address is 0004.4d82.7981 (bia)
  Hello time 4 sec, hold time 12 sec
    Next hello sent in 1.412 secs
  Preemption enabled, min delay 50 sec, sync delay 40 sec
  Active router is local
  Standby router is 10.1.0.6, priority 75 (expires in 9.184 sec)
  Priority 95 (configured 120)
    Tracking 2 objects, 0 up
      Down Interface Ethernet0/2, pri 15
      Down Interface Ethernet0/3
  IP redundancy name is "HSRP1", advertisement interval is 34 sec
```

- A.Router A will assume the active state if its priority is the highest.
- B.If Ethernet 0/2 goes down, the standby router will take over.
- C.When Ethernet 0/3 of RouterA comes back up, the priority will become 105.
- D.The local IP address of Router A is 10.1.0.6.
- E.The local IP address of Router A is 10.1.0.20.

Answer: A C

8: In the use of 802.1X access control, which three protocols are allowed through the switch port before authentication takes place? (Choose three.)

- A.STP
- B.CDP
- C.EAP MD5
- D.TACACS+
- E.EAP-over-LAN
- F.protocols not filtered by an ACL

Answer: A B E

9: Refer to the exhibit. The web servers WS\_1 and WS\_2 need to be accessed by external and internal users. For security reasons, the servers should not communicate with each other, although they are located on the same subnet. The servers do need, however, to communicate with a database server located in the inside network. What configuration will isolate the servers from each other?

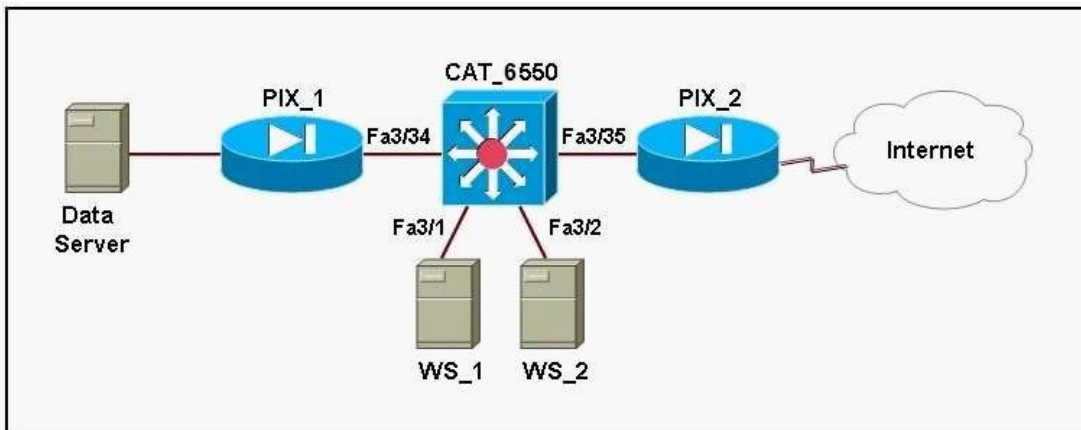

- A. The switch ports 3/1 and 3/2 will be defined as secondary VLAN isolated ports. The ports connecting to the two firewalls will be defined as primary VLAN promiscuous ports.
- B. The switch ports 3/1 and 3/2 will be defined as secondary VLAN community ports. The ports connecting to the two firewalls will be defined as primary VLAN promiscuous ports.
- C. The switch ports 3/1 and 3/2 and the ports connecting to the two firewalls will be defined as primary VLAN promiscuous ports.
- D. The switch ports 3/1 and 3/2 and the ports connecting to the two firewalls will be defined as primary VLAN community ports.

Answer: A

10: Refer to the exhibit. Which two Lightweight Access Point statements are true? (Choose two.)

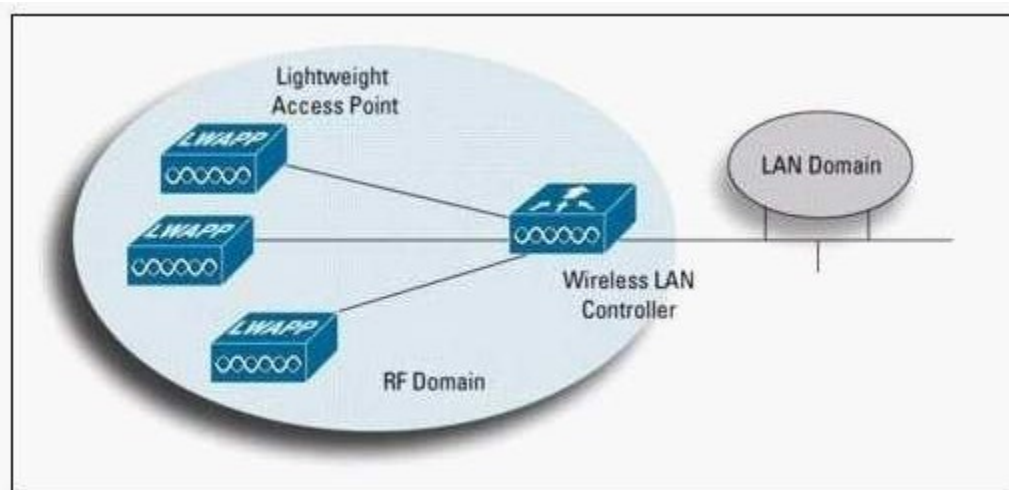

- A. An AP that has been upgraded from an autonomous AP to lightweight AP will only function in conjunction with a Cisco Wireless LAN controller.
- B. Autonomous APs receive control and configuration information from a WLAN controller.
- C. LWAPP increases the amount of processing within the APs, enabling them to support filtering and policy enforcement features.
- D. Real time events such as authentication, security management, and mobility are handled by the lightweight AP.
- E. Lightweight APs require local configurations using local management.
- F. WLAN controllers provide a single point of management.

Answer: A F

11: Refer to the exhibit. Which Catalyst switch interface command would be used to cause the switch to instruct the phone to override the incoming CoS from the PC before forwarding the packet to the switch?

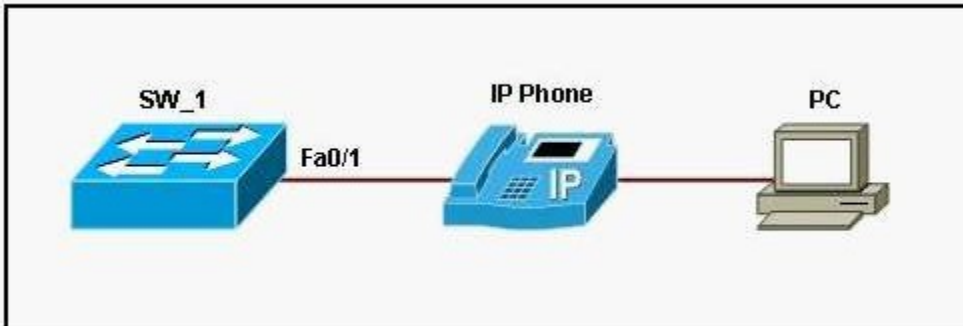

- A.switchport priority extend none
- B.switchport priority extend trust
- C.switchport priority extend cos 2
- D.switchport priority extend cos 11
- E.mls qos cos 2
- F.mls qos cos 2 override

Answer: C

12: Which two Lightweight Access Point Protocol (LWAPP) statements are true? (Choose two.)

- A.Control traffic is encapsulated in UDP packets with a source port of 1024 and a destination port of 12223.
- B.Control traffic is encapsulated in TCP packets with a source port of 1024 and a destination port of 12223.
- C.Data traffic is encapsulated in UDP packets with a source port of 1024 and a destination port of 12223.
- D.Data traffic is encapsulated in TCP packets with a source port of 1024 and destination port of 12223.
- E.Layer 3 LWAPP is a UDP / IP frame that requires a Cisco Aironet AP to obtain an IP address using DHCP.
- F.LWAPP is a proprietary protocol, and because of its very high overhead it is not widely adopted .

Answer: A E

13: LAB

The headquarter offices for a book retailer are enhancing their wiring closets with Layer3 switches. The new distribution-layer switch has been installed and a new access-layer switch cabled to it. Your task is to configure VTP to share VLAN information from the distribution-layer switch to the access-layer devices. Then, it is necessary to configure interVLAN routing on the distribution-layer switch to route traffic between the different VLANs that are configured on the access-layer switches; however, it is not necessary for you to make the specific VLAN port assignments on the access-layer switches. Also, because VLAN database mode is being deprecated by Cisco, all VLAN and VTP configurations are to be completed in the global configuration mode. Please reference the following table for the VTP and VLAN information to be configured:

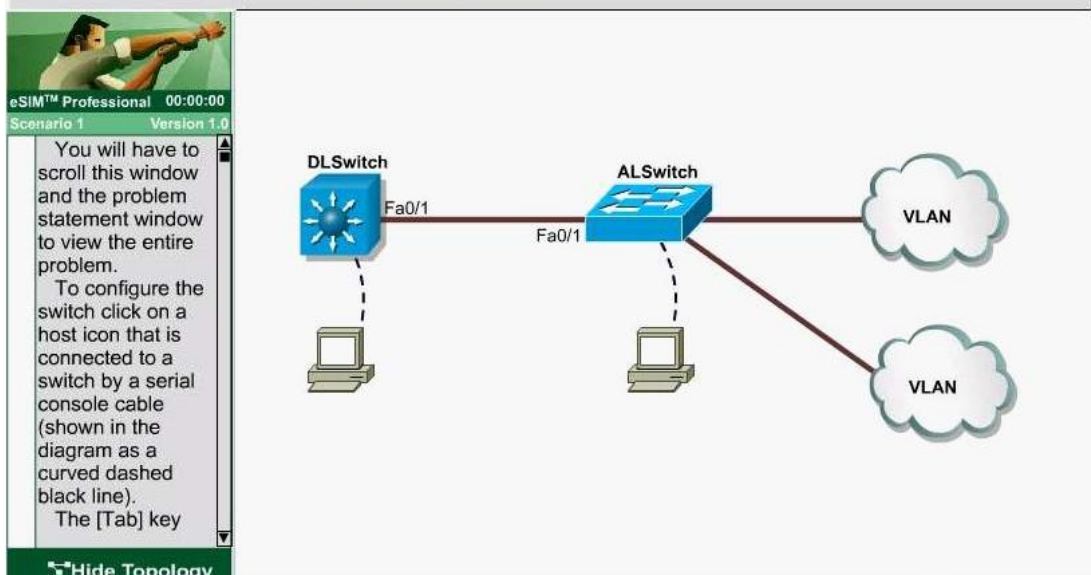

Answer: The information of the question

VTP Domain name : cisco

VLAN Ids 20 31

IP Addresses 172.16.71.1/24 172.16.132.1/24

These are your specific tasks:

1. Configure the VTP information with the distribution layer switch as the VTP server
2. Configure the VTP information with the access layer switch as a VTP client
3. Configure VLANs on the distribution layer switch
4. Configure inter-VLAN routing on the distribution layer switch
5. Specific VLAN port assignments will be made as users are added to the access layer switches in the future.
6. All VLANs and VTP configurations are to be completed in the global configuration. To configure the switch click on the host icon that is connected to the switch by way of a serial console cable.

Correct Answers:

vtp server configuration:

```
switch#conf t
```

```
switch(config)#vtp mode server
```

```
switch(config)#vtp domain CISCO
```

```
switch(config)#vlan 20
```

```
switch(config)#vlan 31
```

```
switch(config)#int vlan 20
```

```
switch(if-config)#ip add 172.64.20.1 255.255.255.0
```

```
switch(if-config)#no shut
```

```
switch(if-config)#int vlan 31
```



```
switch(if-config)#ip add 192.162.31.1 255.255.255.0
switch(if-config)#no shut
switch(if-config)#exit
switch#ip routing
switch#copy run start
```

vtp client configuration:

```
switch#conf t
switch(config)#vtp mode client
switch(config)#vtp domain CISCO
switch#copy run start
```

14: When an attacker is using switch spoofing to perform VLAN hopping, how is the attacker able to gather information?

- A.The attacking station uses DTP to negotiate trunking with a switch port and captures all traffic that is allowed on the trunk
- B.The attacking station tags itself with all usable VLANs to capture data that is passed through the switch, regardless of the VLAN to which the data belongs.
- C.The attacking station will generate frames with two 802.1Q headers to cause the switch to forward the frames to a VLAN that would be inaccessible to the attacker through legitimate means.
- D.The attacking station uses VTP to collect VLAN information that is sent out and then tags itself with the domain information in order to capture the data.

Answer: A

15: LAB

The headquarter office for a cement manufacturer is installing a temporary Catalyst 3550 in an IDF to connect 24 additional users. To prevent network corruption, it is important to have the correct configuration prior to connecting to the production network. It will be necessary to ensure that the switch does not participate in VTP but forwards VTP advertisements that are received on trunk ports.

Because of errors that have been experienced on office computers, all nontrunking interfaces should transition immediately to the forwarding state of Spanningree. Also, configure the user ports (all FastEthernet ports) so that the ports are permanently nontrunking.

The screenshot shows the eSIM Professional software interface. On the left, a scenario window titled 'Scenario 1' contains the following text: 'You will have to scroll this window and the problem statement window to view the entire problem. To configure the switch click on a host icon that is connected to a switch by a serial console cable (shown in the diagram as a curved solid black line). The [Tab] key'. On the right, a diagram shows a computer icon connected to a blue switch icon by a curved black line labeled 'CONSOLE'. At the bottom left of the interface, there is a button labeled 'Hide Topology'.

Answer: The information of the question

You will configure FastEthernet ports 0/12 through 0/24 for users who belong to VLAN 20. Also, all VLAN and VTP configurations are to be completed in global configuration mode as VLAN database mode is being deprecated by Cisco. You are required to accomplish the following tasks:

1. Ensure the switch does not participate in VTP but forwards VTP advertisements received on trunk ports.
2. Ensure all non-trunking interfaces (Fa0/1 to Fa0/24) transition immediately to the forwarding state of Spanning-Tree.
3. Ensure all FastEthernet interfaces are in a permanent non-trunking mode.
4. Place FastEthernet interfaces 0/12 through 0/24 in VLAN 20

Correct Answers:

```
switch#conf t
switch(config)#vtp mode transparent
switch(config)#interface range fa0/1 - 24
switch(config-if-range)#switchport mode access
switch(config-if-range)#spanning-tree portfast
switch(config)#interface range fa0/12 - 24
switch(config-if-range)#switchport access vlan 20
switch(config-if-range)#end
switch# copy run start
```

16: Refer to the exhibit. Switch S1 has been configured with the command spanning-tree mode rapid-pvst. Switch S3 has been configured with the command spanning-tree mode mst. Switch S2 is running the IEEE 802.1D instance of Spanning-Tree. What will be the result?

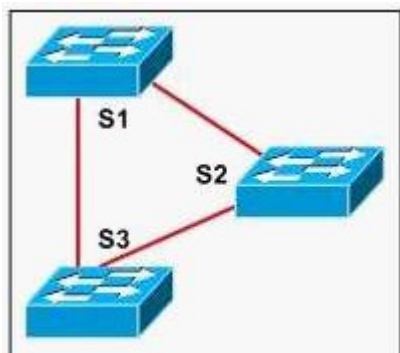

- A. IEEE 802.1w, and IEEE 802.1s are compatible. IEEE 802.1d is incompatible. Switches S1 and S3 will be able to pass traffic between themselves. Neither will be able to pass traffic to Switch S2.
- B. Switches S1, S2, and S3 will be able to pass traffic between themselves.
- C. Switches S1, S2, and S3 will be able to pass traffic between themselves. However, if there is a topology change, Switch S2 will not receive notification of the change.
- D. IEEE 802.1d, IEEE 802.1w, and IEEE 802.1s are incompatible. All three switches must use the same standard or no traffic will pass between any of the switches.

Answer: B

17: The network operations center has received a call stating that users in VLAN 107 are unable to access resources through Router 1. From the information contained in the graphic, what is the cause of this problem?

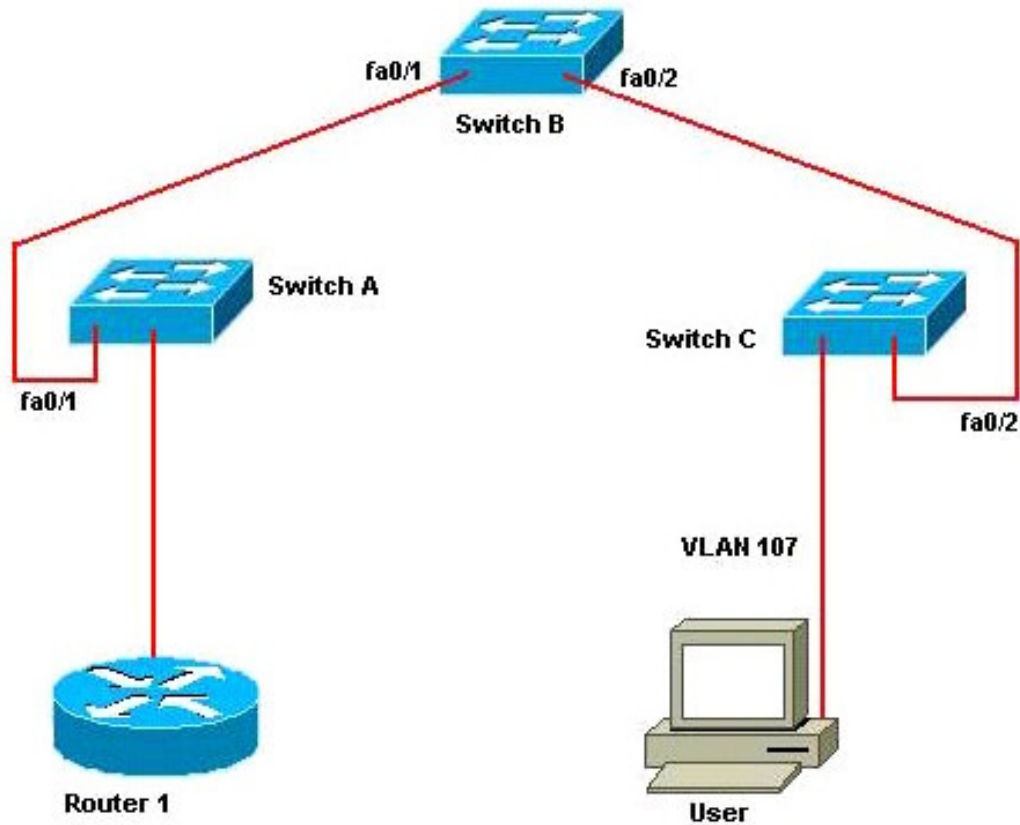

Use the following information from switch A:

Port	Mode	Encapsulation	Status	Native VLAN
fa0/1	desirable	n-802.1q	trunking	5
Port fa0/1	VLANs allowed on trunk 1-100, 102-1005			
Port fa0/1	VLANs allowed and active in management domain 1-6, 8-100, 102-105, 107-999, 1002-1005			
Port fa0/1	VLANs in spanning tree forwarding state and not pruned 1-6, 8-100, 102-105, 108-999, 1002-1005			

- A.VLAN 107 does not exist on switch A.
- B.VTP is pruning VLAN 107
- C.VLAN 107 is not configured on the trunk
- D.spanning tree is not enabled on VLAN 107

Answer: B

18: Refer to the exhibit. Which interface or interfaces on switch SW\_A can have the port security feature enabled?

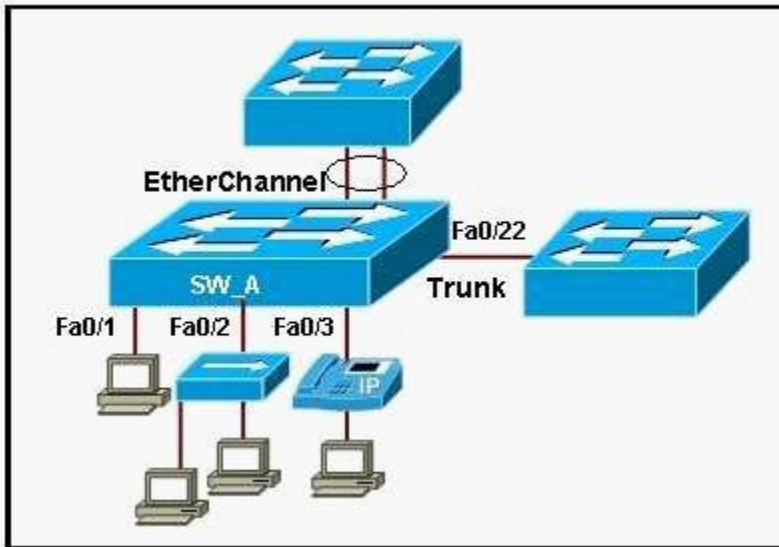

- A.Port 0/1
  - B.Ports 0/1 and 0/2
  - C.Ports 0/1, 0/2 and 0/3
  - D.Ports 0/1, 0/2, 0/3 and the trunk port 0/22
  - E.The trunk port 0/22 and the EtherChannel ports
  - F.Ports 0/1, 0/2, 0/3, the trunk port 0/22 and the EtherChannel ports
- Answer: C

19: Refer to the exhibit. Which statement is true about the display of the command show pagp 1 neighbor command?

```
Switch# show pagp 1 neighbor
Flags: S - Device is sending Slow hello.  C - Device is in Consistent state.
      A - Device is in Auto mode.         P - Device learns on physical port.

Channel group 1 neighbors
Port      Partner          Partner          Partner          Partner Group
Name      Name              Device ID        Port              Age  Flags  Cap.
-----
Gi0/1    vegas-p2          0002.4b29.4600  Gi0/1             9s  SC    10001
Gi0/2    vegas-p2          0002.4b29.4600  Gi0/2             24s SC    10001
```

- A.STP packets are sent out the Gi0/1 interface only.
  - B.STP packets are sent out both the Gi0/1 and Gi0/2 interfaces.
  - C.CDP packets are sent out the Gi0/1 interface only.
  - D.CDP packets are sent out the Gi0/2 interface only.
- Answer: A

20: Refer to the exhibit. Which statement is true?

```
Router(config)# vlan access-map pass 10
Router(config-access-map)# match ip address ABC
Router(config-access-map)# action forward
Router(config)# vlan filter pass vlan-list 5-10
```

- A.IP traffic matching access list ABC is forwarded through VLANs 5-10.
- B.IP traffic matching VLAN list 5-10 will be forwarded, and all other traffic will be dropped.
- C.All VLAN traffic matching VLAN list 5-10 will be forwarded, and all traffic matching access list ABC is dropped.
- D.All VLAN traffic in VLANs 5-10 that match access list ABC will be forwarded, and all else will be dropped.

Answer: D

21: What is the default VTP advertisement for subset advertisements in Catalyst switches that are in server or client mode?

- A.5 seconds
- B.10 seconds
- C.30 seconds
- D.1 minute
- E.5 minutes

Answer: E

22: Refer to the exhibit. What is the effect when the switchport priority extend cos 3 command is configured on the switch port interface connected to the IP phone?



- A.Effectively, the trust boundary has been moved to the PC attached to the IP phone.
- B.The computer is now establishing the CoS value and has effectively become the trust boundary.
- C.The IP phone is enabled to override with a CoS value of 3 the existing CoS marking of the PC attached to the IP phone.
- D.The switch will no longer tag incoming voice packets and will extend the trust boundary to the distribution layer switch.
- E.RTP will be used to negotiate a CoS value based upon bandwidth utilization on the link.

Answer: C

23: Which three statements are correct with regard to the IEEE 802.1Q standard? (Choose three.)

- A.the packet is encapsulated with a 26 byte header and a 4 byte FCS
- B.the IEEE 802.1Q frame format adds a 4 byte field to a Ethernet frame
- C.the IEEE 802.1Q frame retains the original MAC destination address
- D.the IEEE 802.1Q frame uses multicast destination of 0x01-00-0c-00-00
- E.protocol uses point-to-point connectivity
- F.protocol uses point-to-multipoint connectivity

Answer: B C E

24: What action should a network administrator take to enable VTP pruning on an entire management domain?

- A.enable VTP pruning on any client switch in the domain

- B.enable VTP pruning on every switch in the domain
- C.enable VTP pruning on any switch in the management domain
- D.enable VTP pruning on a VTP server in the management domain

Answer: D

25: Refer to the exhibit. Port security has been configured on the switch port Fa0/5. What would happen if another device is connected to the port after the maximum number of devices has been reached, even if one or more of the original MAC addresses are inactive?

```
hostname SW_3550
!
<output omitted>
!
interface fastethernet0/5
  switchport mode access
  switchport port-security
  switchport port-security violation protect
  switchport port-security maximum 11
  switchport port-security aging time 0
```

- A.The port will permit the new MAC address because one or more of the original MAC addresses are inactive.
- B.The port will permit the new MAC address because one or more of the original MAC addresses will age out.
- C.Although one or more of the original MAC addresses are inactive, the port will not permit the new MAC address.
- D.Because the new MAC address is not configured on the port, the port will not permit the new MAC address.

Answer: C

26: Refer to the exhibit. On the basis of the information displayed in the exhibit, which statement is true?

```
1230AG# configure terminal
1230AG(config)# configure interface dot11radio 0
1230AG(config-if)# ssid batman
1230AG(config-ssid)# authentication open mac adam alternate eap adam
1230AG(config-ssid)# end
```

- A.Wireless clients will be successfully authenticated only if both their MAC address and EAP key match.
- B.Wireless clients will be successfully authenticated only if their WEP key is configured as "adam".
- C.Wireless clients will first attempt to authenticate with MAC authentication and if this fails, EAP authentication will be attempted.
- D.Wireless clients will first attempt to authenticate with MAC authentication and if this succeeds, EAP

authentication will then be performed.

E. Wireless clients will attempt EAP authentication first, then MAC authentication.

Answer: C

27: What are three possible router states of HSRP routers on a LAN? (Choose three.)

A. standby

B. established

C. active

D. idle

E. backup

F. init

Answer: A C F

28: What is the effect of configuring the following command on a switch? `Switch(config) # spanning-tree portfast bpdupfilter default`

A. If BPDUs are received by a port configured for PortFast, then PortFast is disabled and the BPDUs are processed normally.

B. If BPDUs are received by a port configured for PortFast, they are ignored and none are sent.

C. If BPDUs are received by a port configured for Portfast, the port will transition to forwarding state.

D. The command will enable BPDU filtering on all ports regardless of whether they are configured for BPDU filtering at the interface level.

Answer: A

29: When a wireless client is being configured via the use of Cisco ADU, what are three options that can be set under the Advanced tab in Profile Management? (Choose three.)

A. Pre-Shared Key (Static WEP)

B. SSID

C. Multicast Packet Filtering

D. Transmit Power Level

E. Network Type

F. 802.11b Preamble

Answer: D E F

30: What is the correct sequence of steps that a wireless client takes during the process of association with an access point (AP)?



<b>A</b>	<b>Client initiates association process.</b>
<b>B</b>	<b>Access point accepts association of the client.</b>
<b>C</b>	<b>Client sends probe request.</b>
<b>D</b>	<b>Access point sends probe response or beacon.</b>
<b>E</b>	<b>AP adds client MAC address to association table.</b>

A.A, B, C, D, E

B.B, C, D, E, A

C.C, D, A, B, E

D.D, B, C, A, E

Answer: C